

# UC65 controller for digital control of actuators PRODUCT AND WARRANTY INFORMATION

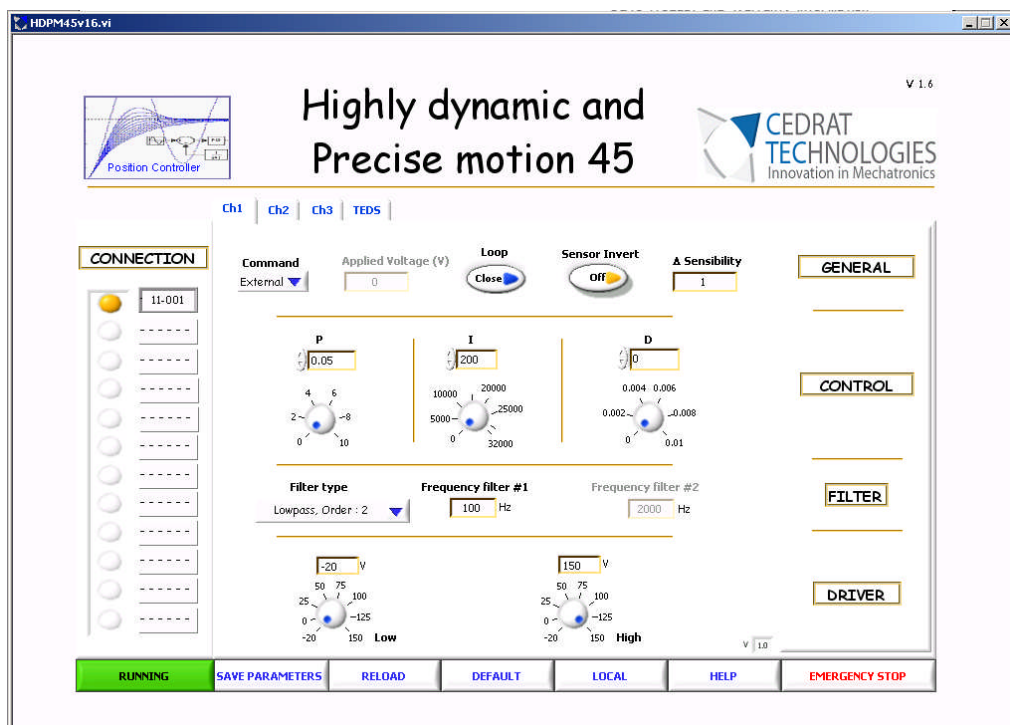

**Version : 1.1**  
**Date: 03/10/2012**

## **CAUTION: READ BEFORE OPENING**

For safety purposes these instructions must be read before use of this product.

This numeric controller is dedicated to control actuators with specific regulators.

The operator must read the user manual related to the driver used CA45, LA75, SA75, or LA24 before powering the UC65 controller.

Only qualified personnel should work on or around this equipment and only after becoming thoroughly familiar with all warnings, safety notices, and procedures contained here in.

The successful and safe operation of this equipment is dependent on proper handling, installation and operation.

A "qualified person" is one who is familiar with the installation, construction and operation of the equipment and the hazards involved. In addition, he/she has the following qualifications :

- is trained and authorized to energize, de-energize, clean, and ground equipment in accordance with established practices,
- is trained in the proper care and use of protective equipment in accordance with established safety practices.

This pictograms  is placed to focus the attention on potential hazards.

## TABLE OF CONTENTS

<b>1.</b>	<b>INTRODUCTION .....</b>	<b>4</b>
<b>2.</b>	<b>GENERAL THEORY .....</b>	<b>5</b>
	2.1. Theory of a control loop.....	5
	2.1.1. <i>The different functions</i> .....	5
	2.1.2. <i>Definition of the regulator</i> .....	7
	2.1.3. <i>Advanced performances</i> .....	10
	2.2. Method of operation with the UC65 controller .....	16
<b>3.</b>	<b>HARDWARE DESCRIPTION .....</b>	<b>17</b>
<b>4.</b>	<b>INSTALLING INSTRUCTIONS .....</b>	<b>18</b>
	4.1. Software Installation .....	18
	4.1.1. <i>Required equipments</i> .....	18
	4.1.2. <i>First time installation</i> .....	18
	4.2. Hardware connections.....	19
<b>5.</b>	<b>"HIGHLY DYNAMIC AND PRECISE MOTION 45" SOFTWARE .....</b>	<b>20</b>
	5.1. Introduction.....	20
	5.2. Connection Section .....	21
	5.3. Parameters section.....	22
	5.4. Transducer Electronic Data Sheet (TEDS).....	24
	5.5. General command section.....	25
	5.6. Summary.....	27
<b>6.</b>	<b>OPERATING INSTRUCTIONS .....</b>	<b>28</b>
	6.1. Step by step instructions .....	28
	6.2. Stand alone application .....	29
	6.3. Single troubleshooting.....	29
<b>7.</b>	<b>FIRMWARE UPGRADE .....</b>	<b>30</b>
<b>8.</b>	<b>TECHNICAL SPECIFICATIONS.....</b>	<b>31</b>
<b>9.</b>	<b>INSPECTION UPON RECEIPT .....</b>	<b>32</b>

## 1. INTRODUCTION

The UC65 board uses a DSP to provide fully digital control of actuators at a rate of up to 60kHz (single channel) with a resolution of 16 bits. It includes a digital PID controller followed by a digital filtering cell. The type of the output filtering cell can be changed, notch of order 2, notch of order 4, low-pass of order 2, or double notch of order 2 for multi-mode controlling. It can also be chosen to have no output filter.

Simply connect the UC65 to the USB port of a computer, and all the control parameters can be modified online using an easy Labview® interface. Once the parameters set, it can be disconnect from the computer and it will run autonomously, keeping the control parameters even after reboot. Thanks to the multi-channel converters, multi-channel control is possible, up to three control channels are available.

Due to the digital nature of the processing, the UC65 has the capability to be adapted to a broad range of other control situations without needing hardware modifications. Thus, it can be adapted to specific actuators requiring a particular control scheme or a hybrid controller.

With the UC65 controller, Cedrat Technologies provides a free NI® licenses software which includes a setup section to modify the parameters of the control loop. With a dedicated regulator, the operator can change the different parameters to optimize the behaviors of the loop in terms of accuracy, speed,...

The UC65 controller is compatible with the different drivers of the standard products. It is integrated in the racks of the standard products up grading the front panel with a USB interface. The dimensions of board are 6F wide, 3H high, for a weight of 0.2Kg.

## 2. GENERAL THEORY

The UC65 controller is used to control actuators in single or multi-channel operation. In multi-channel operation, it is possible to control up to 3 coupled or uncoupled control axis. The UC65 includes multi ADC and DAC converters to sample the analog signals in order to compute the control laws digitally. Before connecting the UC65 controller, the operator will find in the next paragraph the behaviors of each function of the regulator.

### 2.1. Theory of a control loop

#### 2.1.1. The different functions

The basic scheme of one channel control loop is the following. It includes some regulators based on analogue/digital converters and a robust PID controller.

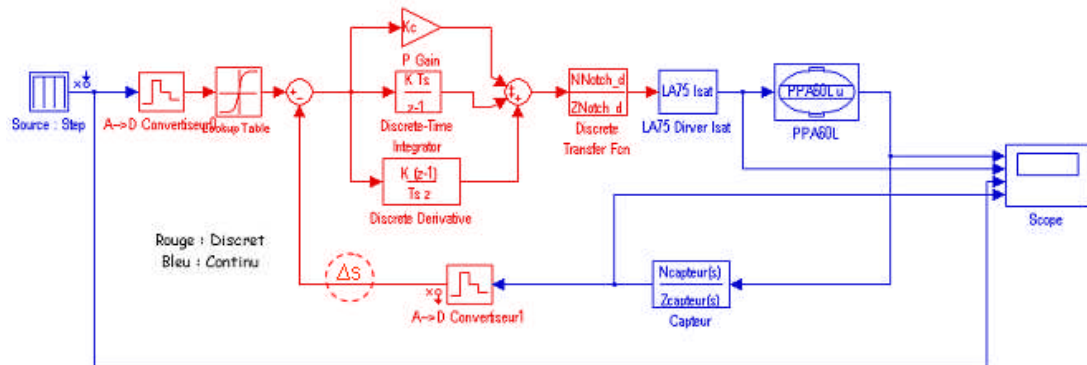

Figure 2-1 - Schematic of a basic digital control loop

Fi

In this example, the displacement of a PPA60L piezo actuator is controlled: each block is represented with an input and an output to model the behavior of the reality. The control loop includes the following blocs:

- The actuator and its driver (in this case the LA75x driver),
- The sensor and its conditioner,

These parts are called the continuous plants and have a continuous behavior (in opposite of digital behavior)

- Two analogue to digital converters including the anti-aliasing filters. These blocs are characterized by sample and hold and quantization functions (the quantization is function of the resolution of the A/D converter, for the UC65 16bits). Those converters are used to sample the analogue orders and feedback signals.
- A digital to analogue converter with 16bits resolution to convert the digital command in an analogue command applied on the actuator. This bloc is generally characterized with the maximum range and the resolution in terms of bits.
- The regulator which computes the error between the command and the real position monitored by the sensor applied through a specific controller an order. The

controller is computed to maintain a closed loop stable with the desired performances (accuracy, speed,...)

- A  $\Delta$  Sensibility gain to adjust sensibility of the data's sensor. (see §2.1.3.2)

### 2.1.2. Definition of the regulator

A feedback controller is implemented in the regulator. It includes a PID regulator in series with a dedicated filter.

A filter is placed inline to limit the effect of the resonant frequency of the actuator. In the case of the actuator is characterized with a low quality factor, this filter can be bypassed and only an adjustment of the PID parameters can optimize the behavior of the loop.

A PID controller attempts to correct the error between a measured process variable and a desired set point by calculating and then outputting a corrective action that can adjust the process accordingly.

It is used to ensure an optimum response behavior of the actuator to its input commands- reducing error in velocity, acceleration and mainly in position.

#### PID regulator:

**P=Proportional Gain** - This term determines the overall responses of a system to position errors, providing an output signal proportional to the error at any time low proportional gain provides a system which is very stable (without oscillation, i.e. stable), has low stiffness and possibility large position errors under load. A high proportional gain provides high stiffness and small position errors under load, but may be unstable.

**I= integral Gain** - This term helps the system to eliminate positional errors but in static condition by increasing the output to the actuator until the error reduces to zero. This error is added or integrated over time and eventually the controller generates a sufficient output to reduce it. A low Integral gain may allow positional error at rest, which depends on the static load.

**D=Derivative Gain** - this term provides damping and stability to the system by preventing overshoot.

On the following frequency response, the impact of each term is traced.

Effect of the I term      Effect of the P term      Effect of the D term

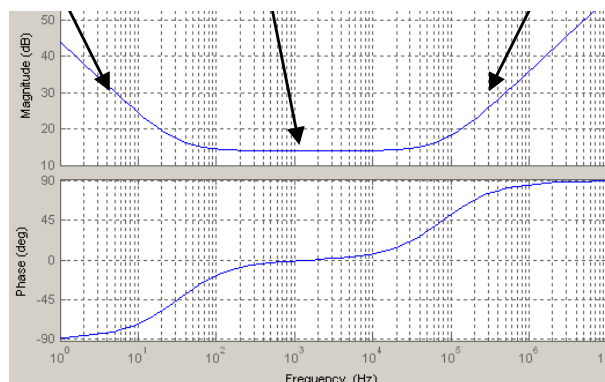

Figure 2-2 - Frequency response of a PID controller

Generally the PID regulator can be written with the following formulae:

$$y(t) = \varepsilon(t) \times P + \frac{1}{I} \int \varepsilon(t) dt + D \times \frac{d\varepsilon(t)}{dt}$$

With the  $j\omega$  operator:

$$\frac{y(j\omega)}{\varepsilon(j\omega)} = \frac{D \times (j\omega)^2 + I \times (j\omega) + P}{j\omega}$$

Where:  $y(j\omega)$  is the output of the regulator,  $\varepsilon(j\omega)$  is the input of the regulator or the error.

Generally to suppress high frequency noise the D term is limited with a 1<sup>st</sup> order low pass filter to limit the high frequency gain.

Impact of the terms:

Closed loop response	Rise time	Overshoot	Settling time	Final error
P	Decrease	Increase	Small change	Decrease
I	Decrease	Increase	Increase	Eliminate
D	Small change	Decrease	Decrease	Small change

Figure 2-3 - Impact of the different parameters on the output

To learn more, please see below §2.1.3. & 5. sections

#### Added filter:

A PID controller can be followed with a filter to limit the impact of the resonant frequency of the actuator. Two factory tuned types of filters are implemented in the controller:

- The first one is a 2<sup>nd</sup> order low pass filter which has a low cut off frequency to reduce with its roll off of 40dB/decade the impact of the resonant frequency of the actuator. This filter is well adapted for static applications where a low bandwidth is required.
- The second one is a 2<sup>nd</sup> order notch filter placed at the resonant frequency of the actuator (see the next paragraph for more detail). This filter is well adapted for applications which require more bandwidth.

In any case, these filters increase the time response of the actuators to reach the desired position.

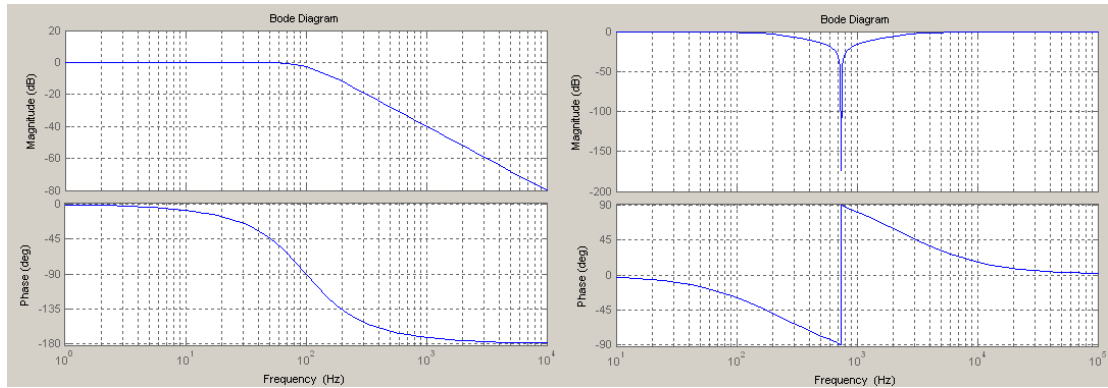

Figure 2-4 - Frequency response of different ideal filters: low pass filter and Stop band filter

The low pass filter is a 2<sup>nd</sup> order low pass Butterworth filter described with the following formulae:

$$\frac{Out(j\omega)}{In(j\omega)} = \frac{1}{(j\omega)^2 + 2 \times z \times j\omega + 1}$$

With  $\omega_o$ , the cut off pulsation of the filter and z the damping.

The stop band filter is a 2<sup>nd</sup> order stop band Butterworth filter described with the following formulae:

$$\frac{Out(j\omega)}{In(j\omega)} = \frac{\left(\frac{j\omega}{\omega_o}\right)^2 + 1}{\left(\frac{j\omega}{\omega_o}\right)^2 + \frac{j\omega}{\omega_o} \times 2 \times z + 1}$$

With  $\omega_o$ , the centre pulsation of the filter and z the damping.

To learn more, please see below §2.1.3. & 5. sections.

### 2.1.3. Advanced performances

#### 2.1.3.1. Control

For people who want to understand the impact of such filters described below (frequency, type) / PID parameters this section gives some details/inputs to study the behavior of the control loop and the impact of these elements and how the operator must analyze the loop.

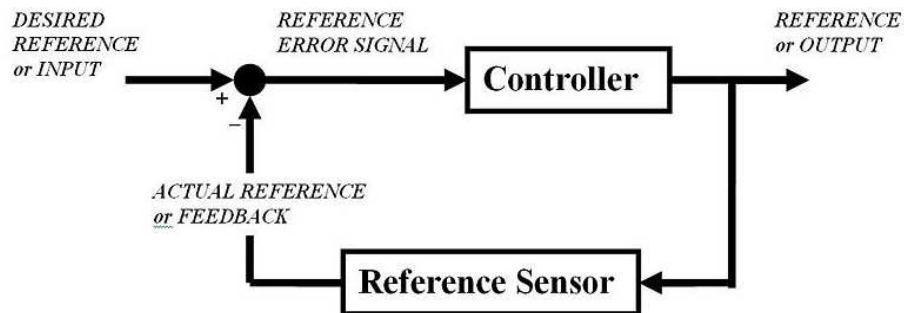

Figure 2-5 - Schematic of a feedback loop

A common process begins with the study of the behavior in open loop and in closed loop. In this case, we will define the phase and gain margins with additional filters working as stabilizing filters.

The steps to optimize the closed loop are the following:

1. Definition of the models with the different blocks constituting the entire loop (continuous plant, acquisition, treatment, drivers, sensors,...),
2. Choice of the type of regulator with analyze in open loop and closed loop in the frequency and transient domains,
3. Tests in the real world.

To develop these stages, we will use the example of the position control of a PPA60L piezo actuator with a strain gage position sensor. The next figure represents this position loop:

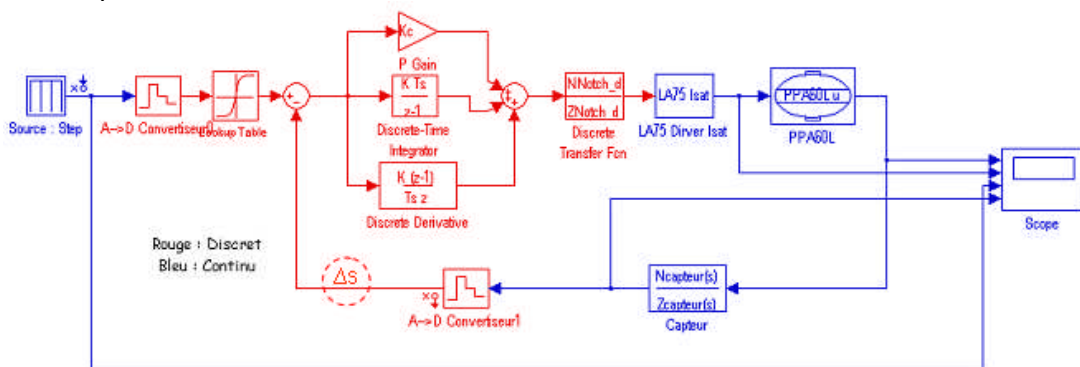

Figure 2-6 - Schematic of a Position control loop

Before analyzing the behavior of the loop, a first step is the definition of the model and its accuracy. In quasi-static condition, a model of the piezo actuator with its fundamental mode can be used. (see **Application Note on the numerical control from the standard catalogue of piezo actuators, drivers & controllers ©2007**).

$$H(j\omega) = \frac{u}{V} = \frac{Nc_m}{1 + r_m c_m j\omega + m_m c_m (j\omega)^2}$$

This transfer function represents the displacement of the actuator in function of the applied voltage on the ceramics. This transfer function of course is linear and doesn't take into account the creep effect or the intrinsic hysteresis. (If necessary we suggest to use simulation software to include these nonlinearities)



**Caution:** When high settling time is required, the elementary model is not enough to be used in the complete model. We suggest a modal identification from Finite Element Model software of the mechanism or a hardware-in-the loop identification process to take into account the other modes at higher frequency.

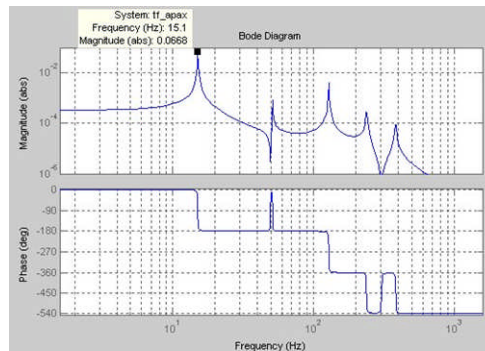

Figure 2-7 - Modal identification of a mechanism

In first approximation (for quasi-static application), the driver is a pure gain. You should integrate the current limitation when the system requires bandwidth.

$$Driver(j\omega) = \frac{Out}{In} = 20$$

A sensor can be represented with a pure gain. If you use a strain gages sensor from Cedrat Technologies (SG75 board), this gain is defined as:

$$Sensor(j\omega) = \frac{Out}{In} = \frac{Maximal\_stroke}{Maximal\_input\_voltage}$$

Numerical application: For an APA120ML, the maximum stroke is 120µm and the maximum voltage order is 8.5V: The gain is 70833 V/m

The study can be realized in continuous domain in which the controller is represented by a continuous transfer function without frequency limitation from the sample rate of the loop or in discrete domain where the controller is digitalized and represented with

a z transfer function. In this case, the loop includes the sample & hold and the quantization of the analogue to digital converter and the digital to analogue converter. The aim of the control is to increase the accuracy, the settling time without destabilizing the loop. The last point is very important and must follow a specific study.

Stability (in control theory) often means that for any bounded input over any amount of time, the output will also be bounded. This is known as BIBO stability (see also Lyapunov stability). If a system is BIBO stable then the output cannot "blow up" (i.e., become infinite) if the input remains finite. Mathematically, this means that for a causal linear system to be stable all of the poles of its transfer function must satisfy some criteria depending on whether a continuous or discrete time analysis is used:

- In continuous time, the Laplace transform is used to obtain the transfer function. A system is stable if the poles of this transfer function lie in the closed left half of the complex plane. I.e. the real part of all the poles is less than or equal to zero).

OR

- In discrete time the Z-transform is used. A system is stable if the poles of this transfer function lie on or inside the unit circle. I.e. the magnitude of the poles is less than or equal to one)

The study of the stability of the loop must be realized in parallel of the study of the performance: "A good choice in term of performance can bring an unstable system".

The study of the stability is directly linked to the open loop transfer function. The following diagram shows an alternative representation of a feedback loop.

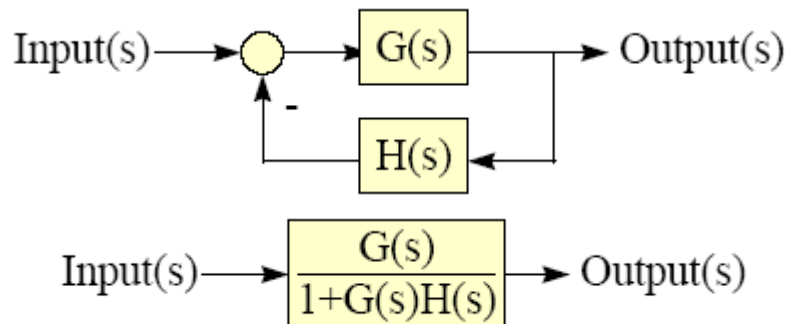

Figure 2-8 - General representation of a feedback loop

The stability is the study of the equation  $1 + G(s)H(s) = 0$  with  $G(s)$  the plant in line with the controller and  $H(s)$  the sensor.  $G(s)H(s)$  is called the open loop transfer function.

Instability occurs when the denominator in Figure 10 becomes zero. In other words, when  $G(s)H(s) = -1$ .

This equation can be resolved with mathematic formulae but it is easier to trace in the frequency domain the module and the argument of this transfer function.

- $P_n$  are real negative  $\rightarrow$  stable system,
- $P_n$  are complex with real negative parts  $\rightarrow$  critically stable system,

- Pn are imaginary complex → Unstable system.

Recalling that 0 dB is equivalent to unity, -1 can be written as 0dB -180°. We introduce the Bode diagram as a representation in the frequency domain of the module and argument of a transfer function. The open-loop method works by estimating two measures of stability or *margins*. The first is *phase margin* or *PM*. Find PM by locating the frequency where the loop gain is 0 dB.

*Gain margin* or *GM* is similar. Find the frequency where the open-loop phase is -180° and then measure the gain. Since the system will be unstable at 0dB -180°, the *GM* is 0dB less the gain.

→ Example: Open loop transfer function and their margins.

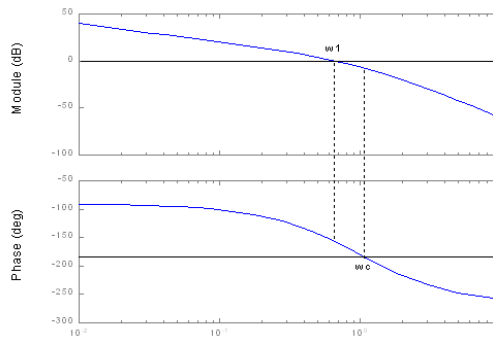

Figure 2-9 - Frequency response of the open loop transfer function- Bode diagram

The study of the performances is based on the study of  $\frac{G(s)}{1 + G(s)H(s)}$  in closed loop. To optimize the response to a step, we analyze the transfer function:

$$\frac{\text{Output}}{\text{Input}} = \frac{G(s)}{1 + G(s)H(s)}$$

To optimize the regulation of the impact of the disturbance, the operator must analyze the next transfer function:

$$\frac{\text{Disturbance}}{\text{Input}} = \frac{1}{1 + G(s)H(s)}$$

In any case if  $GH \gg 1$  then Input = Output for the first equation and Disturbance  $\ll$  Input".

→ Example: Correlation in closed loop

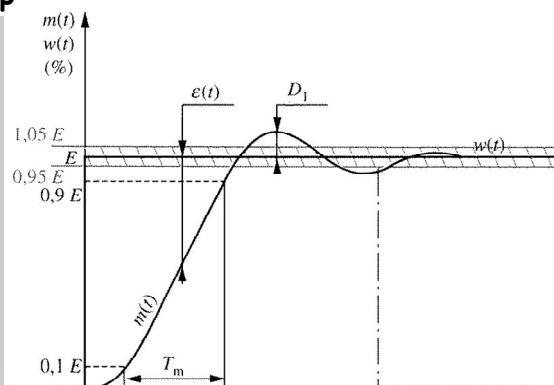
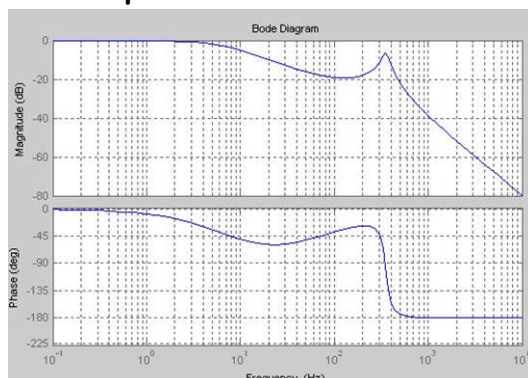

Figure 2-10 - a- Frequency response of the closed loop transfer function, b transient response

We recommend using dedicated software like MATLAB/Simulink from The MATHWORKS® to trace the different Bode diagrams and transient responses. In an actuator with a large peak at its resonant frequency (high quality factor) the PID regulator is generally not sufficient to stabilize the closed loop and the state of the art is to add in line a specific filter defined above. On the following Bode diagram we show the impact of stabilizing filters on a standard analogue PID controller coupled with a piezo-actuator. The stability can be assured with the low pass filter and the placement of the cut off frequency below the resonant frequency of the actuator. A low pass filter or an integrator term slow down the time response of the system.

→ **Example: Impact of the stabilizing filters on open loop/closed loops transfer function/transient responses of a piezo actuator, a PID regulator and some stabilized filters:**

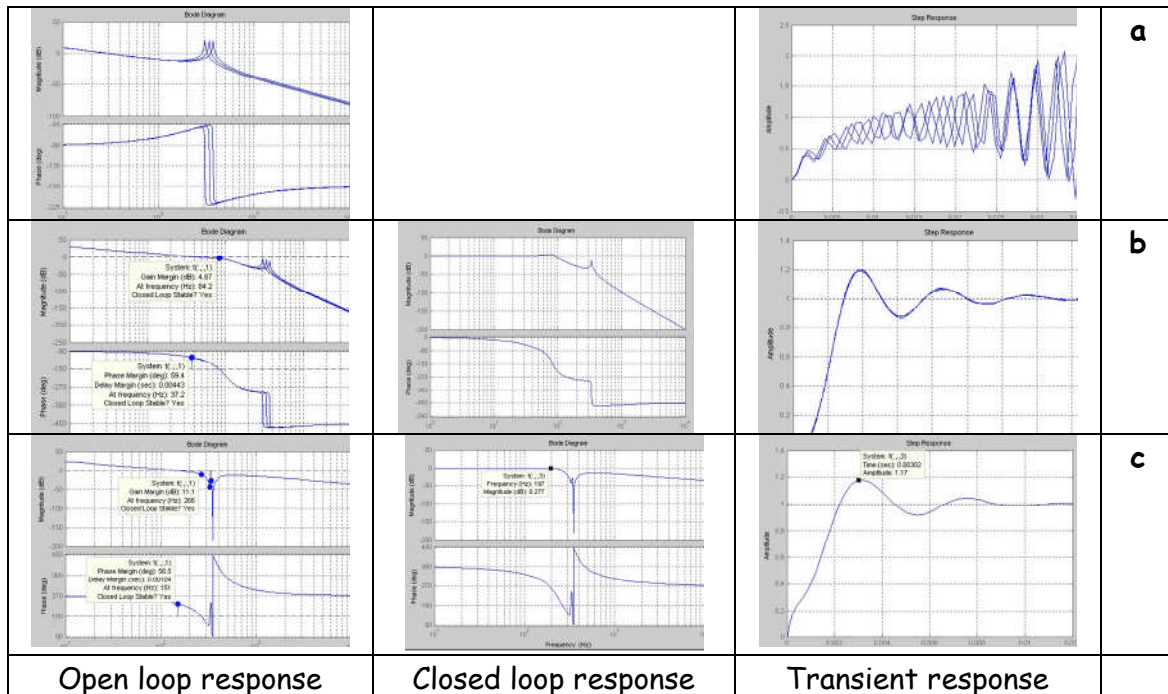

Figure 2-11 - Frequency response of the open loop transfer function/closed loop transfer function and transient response a- without filter, b- with Low pass filter, c- with Notch filter

**Numerical application:**

Input Data :

APA400M with 50gr:

- Q = 100,
- Load = 50gr,
- Fr = 340Hz +/-10%

First case: with a low pass filter: fc=100Hz, 2nd order

Results:

With P=0.1, I=250:

Overshoot: 20%,Stability: 5dB, 60°, Fc in closed loop ≈ 100Hz

Modification PID parameters:  $P=0.1, I=300$

Overshoot: 40%, Stability: 3dB,  $45^\circ, F_c \approx 100\text{Hz}$

The low pass filter fixes the cut off frequency of the closed loop. The I term doesn't play a large role after the cut off frequency of the low pass filter.

Modification Cut off frequency of the low pass filter  $\rightarrow 300\text{Hz}$

Stability: 4dB,  $20^\circ, F_c \approx 150\text{Hz}$ ,

The system is not really stable

Second case: with a Notch filter:  $F_c=Fr, 2\text{nd order}$

Results:

With  $P=0.1, I=1000$  &  $D=1e-4$ :

Overshoot is reduced, Settling time 3ms, Stability: 11dB,  $56^\circ, F_c \approx 200\text{Hz}$  but phase lag at low frequency

Parameters	Without stabilizing filter	With low pass filter	With Notch filter
Closed loop	Practically unstable - stable with a simple model	Stable is Cut-off frequency below $Fr/3$ , Phase lag	Stable is Cut-off frequency equals $Fr$ , Phase lag
Transient response to a step	Practically unstable - stable with a simple model	Low response time	Fast response time

Figure 2-12 - Table of behavior of the loop with different filters.

If the operator wants to reduce the phase lag, the controller is designed without stabilizing filters. In this case, the PID terms must be correctly optimized to increase the phase/gain margin. This condition of operation is not really easy to tune and must be used with caution.

This methodology can be applied directly on other kind of control loop (vibration control, servo speed,...) with only a modification of the sensor block, the regulator.

2.1.3.2.  $\Delta$  Calibration

For people who need a good resolution and who use loaded actuator, this section gives some details to use the  $\Delta$  sensibility.

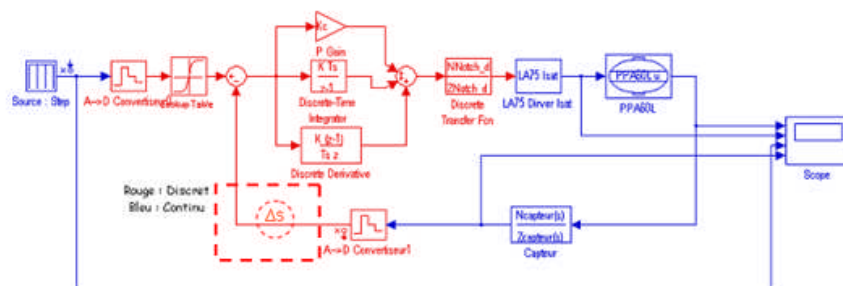

Figure 2-13 :  $\Delta$  s in the position control loop

If the actuator is loaded, the difference between the tension max of loaded and non-loaded actuator will be big. The  $\Delta s$  sensibility permits to adjust the gain in the feedback loop, to avoid this problem. Without this gain adjustment the control will saturate near the tension limits.

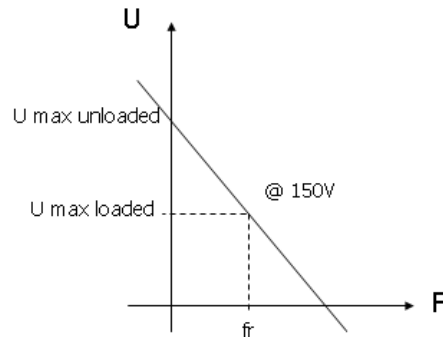

Figure 2-14 - Displacement Vs Frequency

$$\Delta s = U_{\text{max unloaded}} / U_{\text{max loaded}}$$

The default value is  $\Delta s = 1$  and in general  $\Delta s > 1$ . As the  $\Delta s$  is in the feedback loop, the gain will not appear directly on the output measurement.

### Calibration of the $\Delta s$ on HDP45

1. If you can measure the displacement of the actuator  $u_A$  integrated in the system, then  $\Delta s = u_A / u_0$

Where  $u_0$  = Maximum Free Displacement of the actuator at 170V.

2. If you can't measure the displacement of the actuator  $u_A$  integrated in the system, then  $\Delta s = V_{\text{INPUT}} / V_{SG75}$

Where  $V_{\text{INPUT}} = 8.5V$

$V_{SG75}$  = Output pk/pk voltage from the SG75 in open loop.

### End of calibration of the $\Delta s$ on HDP45

## **2.2. Method of operation with the UC65 controller**

The previous theories can be exactly applied on the UC65 controller. The basis of this controller includes the possibility to change the PID parameters and the stabilizing filters. The operator can analyze the behavior of the system to adjust the parameters of the loops via the USB link. When the control parameters are adjusted on the computer, they are automatically saved in a non volatile memory. The UC65 can then be operated stand alone without computer interface.



**Caution:** In factory the configuration is set to predefined parameters. This configuration is robust (stable) but gives a slow response in closed-loop. If a faster response time is needed, the controller should be optimized to the mechanism. Be careful to verify the stability in closed-loop when adjusting the controller. Cedrat-Technologies can help you optimizing the controller.

### 3. HARDWARE DESCRIPTION

The UC65 controller is a board that is integrated on a standard product. The only difference with a standard product is the USB type B interface on the front panel.

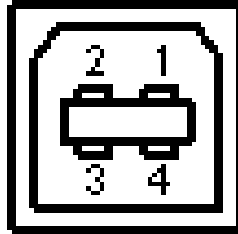

Figure 3-1 : USB B Type on the front panel.

You will need a USB cable with a B Type and a A type to connect to your computer.

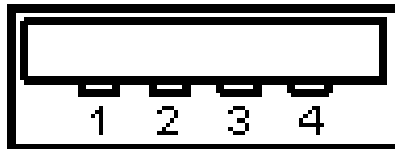

Figure 3-2 : USB A Type on the front panel.

The USB cable will be delivered with the UC65 product by CEDRAT TECHNOLOGIES.

## 4. INSTALLING INSTRUCTIONS

This paragraph describes the different instructions to connect the UC65 controller and to install the computer software. At the same time, the operator must connect the mechanism to the rack following the instruction in the user manual "LA75 - Linear amplifier for piezoelectric actuators - Product and warranty information", or the user manual of the driver in use (LA24, SA75, ...).



DO NOT CONNECT THE USB DRIVER ON THE PC BEFORE INSTALLING THE SOFTWARE.

### 4.1. Software Installation

#### 4.1.1. Required equipments

You must install the Software on the following Personal Computer configuration:

- Change "," in "." in the regional configuration of your PC if it is not the case. (Settings/ Controls Panel / Regional and language Options / Customize / Decimal symbol).
- Your screen cannot be higher than 1200 per 800 pixels.

The installation is simple:

- A unique CD or a download on Cedrat website (<http://www.cedrat.com/en/mechatronic-products/software-download.html?0>) includes the installation of the drivers to dialogue with the UC65 and the installer for the application software. It contains the autonomous application too.

#### 4.1.2. First time installation

1. The operator has to run the " setup.exe" , following the giving indications.

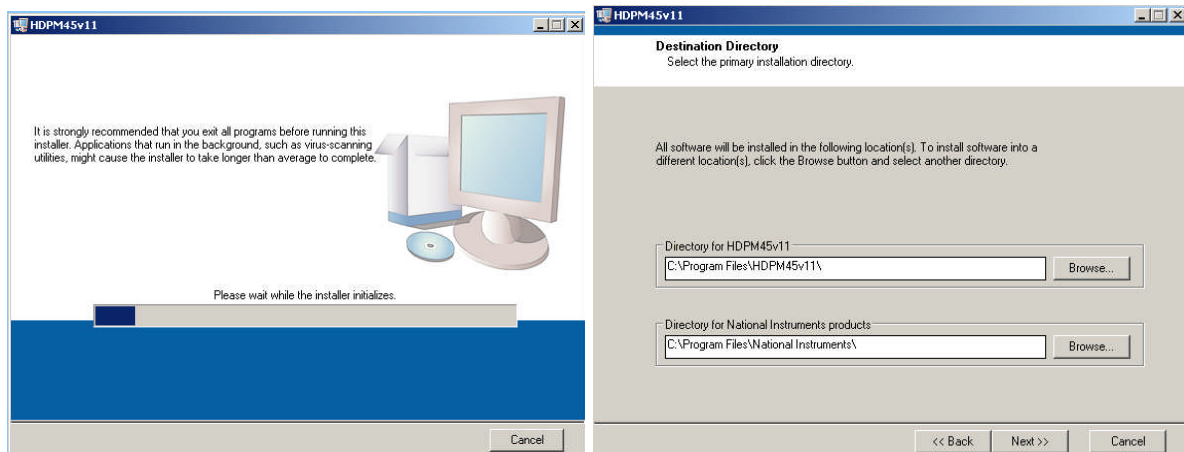

Figure 4-1: Destination directory

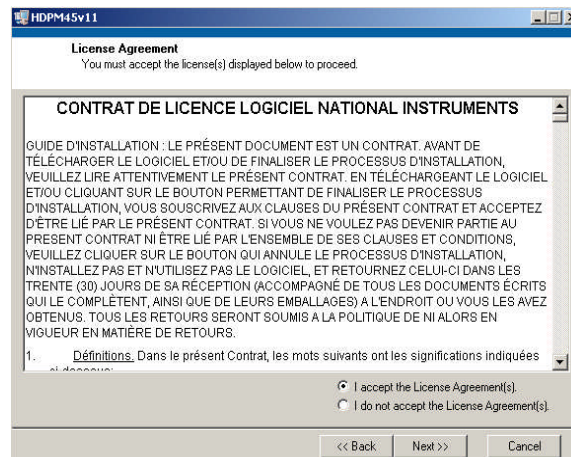

Figure 4-2 : License Agreement.

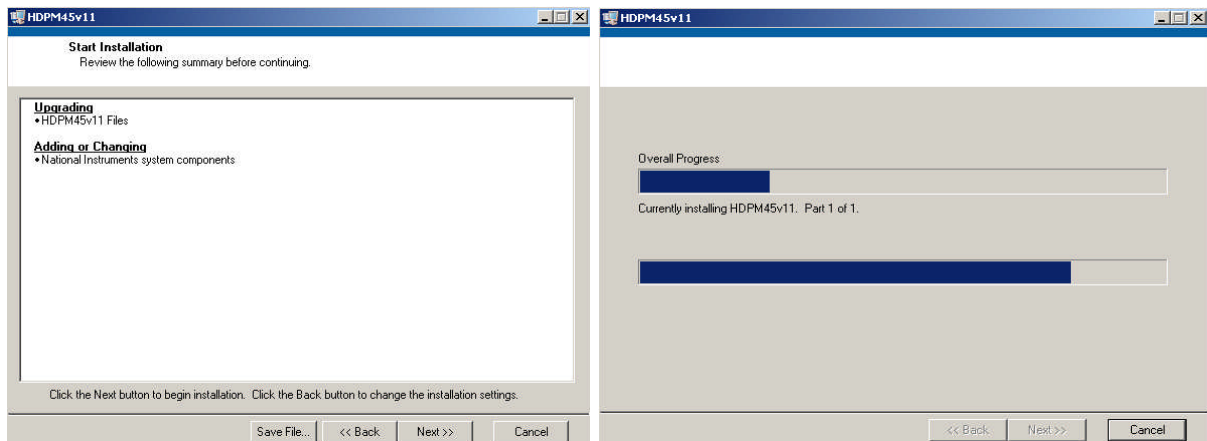

Figure 4-3: Starting Installation.

2. After this installation is finished an other driver will be install automatically, and then **restart** your PC.
3. Connect your PC with the UC65 by USB cable (see 4.2) and power on the rack.
4. Now the operator can run the software "HDP45\_vxx.exe" which is normally on your desktop.

## 4.2. Hardware connections

The hardware connection permits the connection of the UC65 controller to a computer in order to be able to adjust the configuration. Connect the controller with the provided USB cable using the USB port on the controller front panel. If you have too many boards, you can use a USB hub to connect all the boards to the computer.

## 5. “HIGHLY DYNAMIC AND PRECISE MOTION 45” SOFTWARE

### 5.1. Introduction

In this paragraph, we describe how to use the “Highly dynamic and precise motion 45” software with a pair piezo actuator/sensor. The software provided with the UC65 permits to adjust its control configuration. At first, the software make a research of the several boards which could be connected. During this first step, a button **LOADING...** appears. **This first step can be 1 or 2 minutes long.**



Figure 5-1 : First step

During a second step, the software will read the parameters on the boards, a button **NO COMMUNICATION** appears. When those two steps are ok, the Human Machine Interface is ready to use, the button **RUNNING** appears. The screen is cut in three areas :

- The first one on the left manages the several boards.
- The second one on the right manages the regulator with some parameters that the operator can change.
- The last one on the bottom of the screen includes several main commands to manage the state of the software.

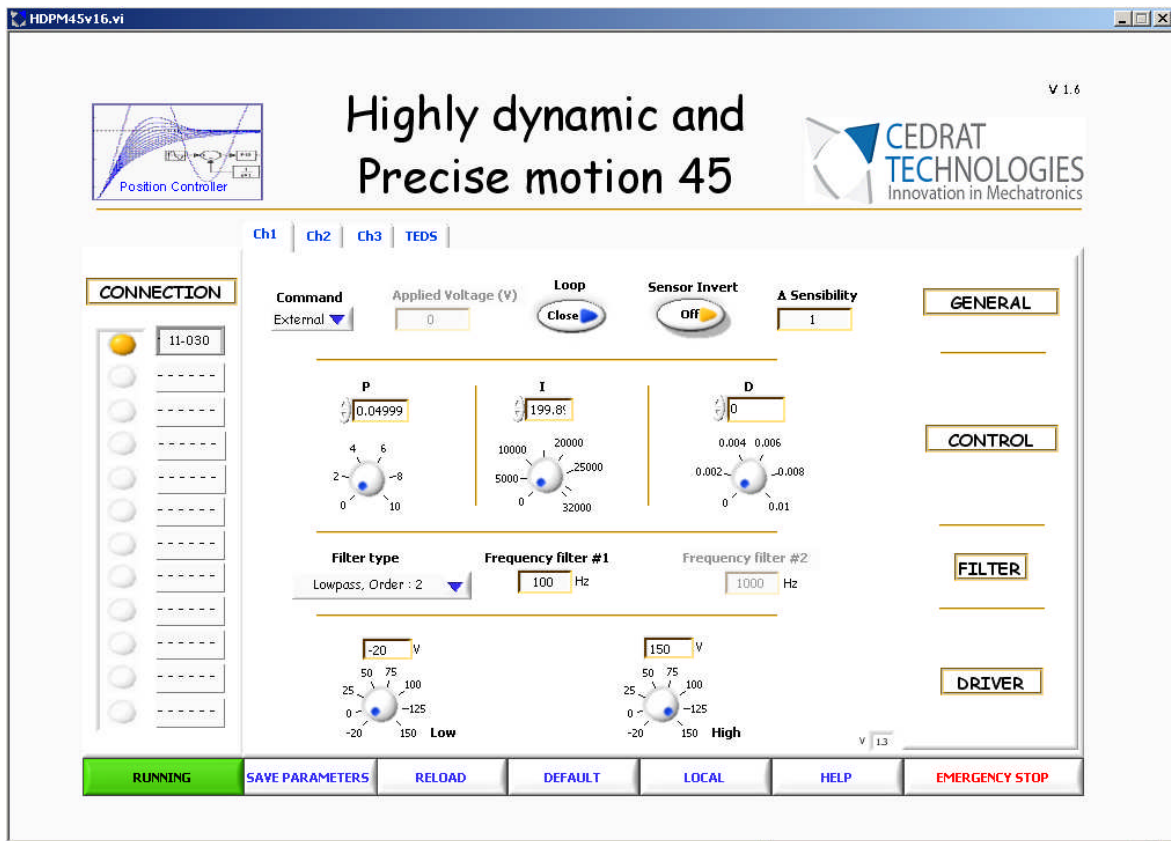

Figure 5-2 : Human Machine Interface description

Each section is named which helps the operator to know what kind of parameter is modified.

### 5.2. Connection Section

On the left side, the screen is composed of twelve possible boards (maximum number). The software search automatically the boards, and the operator can choose the board he wanted to change the parameters:

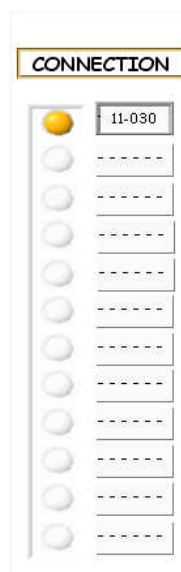

Figure 5-3 : Left section of the HMI : Connection section

Until the connection is not established correctly (button **RUNNING / NO COMMUNICATION** stay in the state **NO COMMUNICATION**), nothing else can be done, except **EMERGENCY STOP**.

### 5.3. Parameters section

On the right side, the screen is composed of four sections where the operator could pass different parameters for the numeric PID controller:

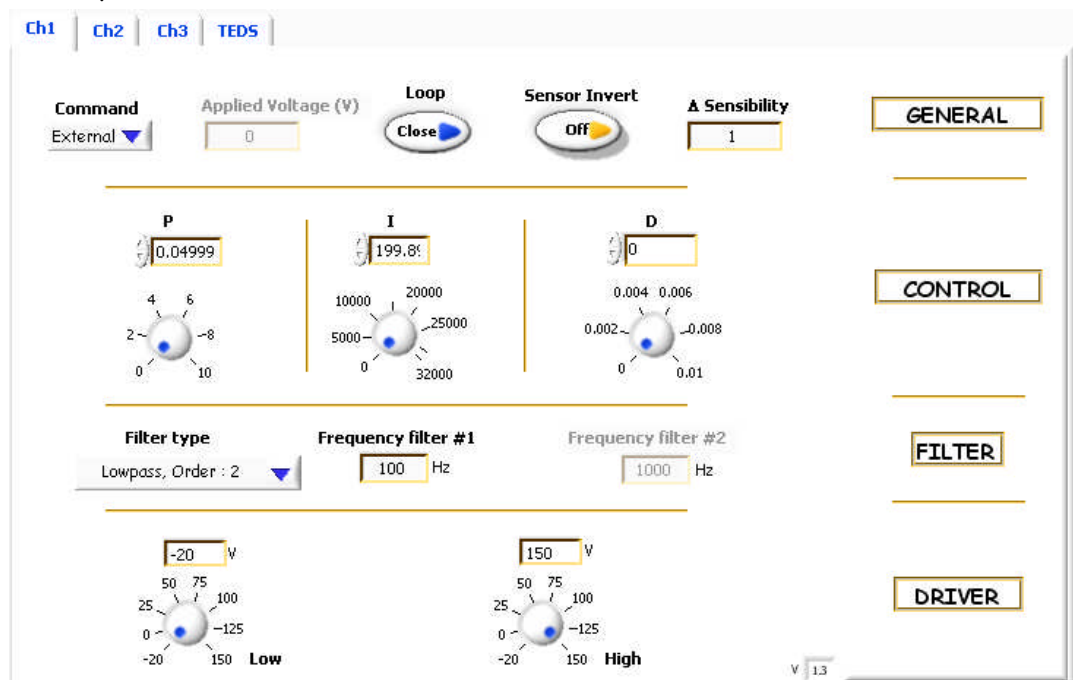

Figure 5-4 : Right section of the HMI: parameter section

#### 1. GENERAL:

- **Command** is a selector to chose between two possible command to send to the actuator:
  - **Internal:** In this case the command is issued from the **Applied voltage command**. The operator can select the voltage that he would like to send on the actuator between -1 to 7.5 Volts.
  - **External:** In this case the command is issued from the Input BNC connector of the CA45 to command the actuator. This command must be adjusted between -1 to 7.5 Volts.
- **Applied voltage command** is used to send on the actuator directly a static command in Volt between -1 to 7.5V.
- **OL/CL** is a command to close or to open the control loop: OL indicates that the controller works in open loop and CL indicates that the controller works in closed loop (i.e. the regulator is on with the parameters in the control section)
- **Sensor Invert** is used to invert the data's sensor.
- **Δ Sensibility** is used to adjust the sensitivity of the feedback sensor.

## 2. CONTROL:

• **P, I, D** commands adjust the PID parameters as described in the previous paragraphs.

- The **P** parameter can be adjusted between 0 to 10 by step of  $1e^{-5}$ .
- The **I** parameter can be adjust between 0 to 32000 by step of  $1e^{-5}$ .
- The **D** term can be adjusted between 0 to  $1e^{-2}$  by step of  $1e^{-5}$ .

The command can be sent by rotating the button or by writing the number independently.

## 3. FILTER:

• **Filter type** indicates the kind of filter is inline with the PID regulator:

- **Low pass, Order: 2** is a filter based on a 2<sup>nd</sup> order low pass filter. In this case only the **frequency filter #1** can be change.
- **Notch, Order: 2** is a filter based on a 2<sup>nd</sup> order stop band filter. In this case only the **frequency filter #1** can be change.
- **Notch, Order: 4** is a filter based on a 4<sup>th</sup> order stop band filter. In this case only the **frequency filter #1** can be change.
- **2 Notches, Order: 2** are two filters based on a 2<sup>nd</sup> order stop band filter. In this case the **frequency filter #1** and the **frequency filter#2** can be change.
- **None** indicates that no filter is added with the PID controller.

• **Frequency filter #1, #2** are integers and can be adjust between 50 to 2000 Hz.

## 4. DRIVER:

- **Low** indicates the lowest limitation of the voltage output of the driver.
- **High** indicates the highest limitation of the voltage output of the driver.

The limitation can be adjusted between -20 to 150V.

These values are correct if the offset of the driver is adjusted at 0 Volt. To verify place the **command** in the **internal** mode (section **General**) and check the value of the driver with an oscilloscope. Turn if necessary the offset potentiometer of the CA45 (see user manual of CA45 for additional information).



We recommend when you tune the regulator to place the **Low** and **High** commands with small amplitudes to limit a potential risk of damage on the actuator during an instability phase by limiting the amplitude of the applied voltage on the actuator.

Each channel can be selected and modified with the Channel button. In a 3 channels configuration the operator can select independently the parameters of each channel for the **GENERAL, CONTROL, FILTER** and **DRIVER** sections.

## 5.4. Transducer Electronic Data Sheet (TEDS)

TEDS is a compact set of data describing sensor calibration characteristics if there is any. Two kinds of sensor can be expected: SG75 or ECS75. For more details on those sensors see the user manuals dedicated to the relative sensor.

Figure 5-5 : TEDS section

### 1. CONTROLLER:

- **Serial Number** of the associated UC65
- **Channel** of the associated UC65

### 2. GENERAL:

- **Sensor** (SG75 or ECS75)
- **Serial number** of the sensor
- **Last Calibration** (DD/MM/YYYY)
- **Calibration period** in month : If the calibration is near to be passed or is passed, a warning will appear to prevent the user.

Cedrat Technologies recommends a recalibration!  
This does not mean that the system is not working properly

Figure 5-6 : Warning on calibration period

- **SNR** (Signal-to-Noise Ratio) in dB
- **Low cut off frequency** at -3dB in Hz
- **High cut off frequency** at -3dB in Hz

### 3. CALIBRATION:

- For SG75:

- Strain gages gain in  $\mu\text{m}/\text{V}$
- Amplifier Gain in  $\text{V}/\text{V}$
- System Gain in  $\mu\text{m}/\text{V}$



Figure 5-7 : SG75 data's

- For ECS75:
  - Gain in  $\mu\text{m}/\text{V}$
  - Linearity error in %



Figure 5-8 : ECS75 Data's

If there are no TEDS associated to the board, the TEDS section will disappear and an indicator "TEDS NOT AVAILABLE" will appear.

### 5.5. General command section

On the bottom side, the screen is composed of several buttons to manage some information:



Figure 5-9 : Bottom section of the HMI: General command section

- **RUNNING/NO COMMUNICATION** button indicates the state of the software:
  - **RUNNING**: No error
  - **NO COMMUNICATION**: A problem is occurred or the communication is temporary not available.



Figure 5-10 : RUNNING/NO COMMUNICATION button: a-No Communication b-Running

- **SAVE PARAMETERS** button permits to save the current parameters in the computer, so that they can be reloaded later on using the **RELOAD** button. **Warning:** The saved parameters are stored in the RAM memory so they can only be recalled during the same session of the HDPM45. If the HDPM45 is stopped, the parameters can not be reloaded.
- **RELOAD** button permits to call back the parameters saved using the **SAVE PARAMETERS** button.
- **DEFAULT** button permits to call back the initial (factory) parameters.
- **LOCAL/REMOTE** button permits to work in stand alone configuration:

- **REMOTE:** The UC65 controller works alone and the USB link is disabled. In this case, the HMI is disconnected from the UC65 controller. To reconnect the HMI with the UC65 controller, click again on the **LOCAL** button to enable the USB link.
- To disconnect the USB link, start by clicking on the **REMOTE** button and disconnect the physical link in a second time. To reconnect the controller to the USB link, start by connecting the physical link and in a second time, select the **LOCAL** button.



Figure 5-11 : LOCAL/REMOTE button: a- LOCAL action, b- REMOTE action

- **HELP** button permits to find the user manual at screen in .pdf format
- **EMERGENCY STOP** permits to stop the software.

## 5.6. Summary

Each parameter are summarized in the following table including their states.

Name	Range
<b>Connection Section</b>	
COM	1 to 12
<b>Parameters Section</b>	
Command	Internal: Command from HMI / External: Command from BNC
Applied Voltage	-1 to 7.5V in Internal mode
OL/CL	OL: Open loop / CL: Closed Loop
Sensor Invert	On : data's sensor invert / Off : data's sensor not invert
$\Delta$ Sensibility	0 to 10 - resolution 1e-5
P	0 to 10 - resolution 1e-5
I	0 to 32000 - resolution 1e-5
D	0 to 1e-2 - resolution 1e-5
Filter type	Low pass, Order : 2 Notch, Order : 2 Notch, Order : 4 2 Notchs, Order : 2 None
Frequency filter #1	Frequency of the filter number 1 - 50 to 2000Hz
Frequency filter #2	Frequency of the filter number 2 - 50 to 2000Hz
Low	-20 to 150V
High	-20 to 150V
<b>TEDS</b>	
Serial Number - UC65	
Channel - UC65	
Sensor	SG75/ECS75
Serial Number of sensor	
Last Calibration	DD/MM/YYYY
Calibration Period	month
SNR in dB	
Low cut off frequency	at -3dB in Hz
High cut off frequency	at -3dB in Hz
Calibration for SG75	Strain Gages gain ( $\mu\text{m}/\text{V}$ ); Amplifier Gain (V/V); System Gain ( $\mu\text{m}/\text{V}$ )
Calibration for ECS75:	Gain in $\mu\text{m}/\text{V}$ ; Linearity error in %
<b>General command section</b>	
RUNNING / NO COMMUNICATION	Display the state of the communication between the PC and the boards.
SAVE PARAMETERS	Save the parameters at the screen.
RELOAD	Call back the parameters from the SAVE PARAMETERS action.
DEFAULT	Call back initial parameters.
HELP	Display a short form of the user manual
LOCAL / REMOTE	REMOTE: The USB link is disable and the HMI is disconnected from the UC65 controller / LOCAL: The USB link is enable and the HMI is connected to the UC65 controller
EMERGENCY STOP	Stop the software

Figure 5-12 : Summarize table of each parameter

## 6. OPERATING INSTRUCTIONS

In this paragraph we give some operating instructions to avoid damages on the mechanism for a first time user.

### 6.1. Step by step instructions

1. Power on the rack by switch on the rear connector. If the rack is not powered on the UC65 microcontroller is not supplied and the HMI is not connected to the microcontroller.
2. Wait until the software is searching the boards (LOADING... button appears).
3. When the connections are ok, the program reads the parameters of the boards. During this time, the **RUNNING / NO COMMUNICATION** button is at the state **NO COMMUNICATION**.
4. When the connections are ok, the program reads the parameters of the boards. During this time, the **RUNNING / NO COMMUNICATION** button is at the state **NO COMMUNICATION**.
5. The parameters are now enabled and the operator can change each parameter.
6. Choose the type of command: **Internal** and **External**. We recommend to check the command signal on an oscilloscope.
7. Don't forget to switch on the CA45 power supply with the mechanical switch in the front panel of the CA45 to provide the power supply to the mechanism.
8. For first time, we recommend to adjust **Low** and **High** with a small Delta voltage to limit the amplitude of the mechanism able to create damage on the mechanism.
9. Adjust **PID** parameters, **Filter** parameter with your application. We recommend remaining in open loop during the modification of these parameters to avoid a typing error and so a bad parameter.
10. Close the loop by clicking on **OL/CL** button. Now the mechanism is controlled in position with the programmed parameters on the HMI. If you hear a sound from the mechanism click immediately on the **OL/CL** button to pass in open loop. The closed loop is unstable! Change the **PID** and **Filter** parameters to be stable.
11. To change the type of command between **Internal** or **External**, we recommend to be in Open loop by clicking on the **OL/CL** button before selecting the new type.
12. To stop the mechanism, the operator must click on the **Emergency Stop** button.

## 6.2. Stand alone application

When the UC65 controller must be configured in a stand alone controller, click on the **REMOTE/LOCAL** button to pass from a **LOCAL** configuration to a **REMOTE** configuration. The controller works continuously but no change can be done. In this configuration the USB link can be disconnected. To modify a parameter, reconnect the USB link and click on the **REMOTE** button to pass in **LOCAL** connection: the HMI and the UC65 controller dialogue together again.

The **REMOTE/LOCAL** button must be pushed when the operator is sure that no new modification of parameters will be done.

## 6.3. Single troubleshooting

Launch the "Highly dynamic and precise motion 45" software with the button on the top and left side.

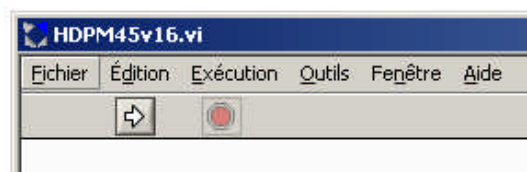

Figure 6-1 : The software is not running.

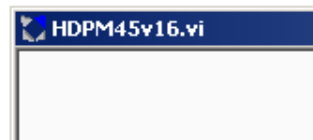

Figure 6-2 : The software is running.

### The UC65 controller doesn't respond:

1. Check the power supply of the rack: the power must be in on state,
2. Check the USB link,
3. Verify the COM address of the board,
4. Run the "Highly dynamic and precise motion 45" software with the button on the top and left side of the screen,
5. The Remote button is in **REMOTE** state and so the controller is in stand alone configuration: To change a parameter or display a curve this button must be in a **LOCAL** configuration.

### The actuator doesn't move:

1. The power is supplied when the mechanical switch in the front panel of the CA45. In this case Protect LED of the CA45 must be lighted,

2. The Type command is in **Internal** position with 0 Volts applied. Pass the type command in **External** position and applied a 1Hz 0.1V square signal on the BNC input connector of the CA45. A little noise must be heard,
3. The type command is in **External** position but no signal is send on the BNC input,
4. In **CL** position the Parameters of the regulator are 0.

**The CL/OL button doesn't respond:**

1. The possibility to pass from Closed loop in Open loop can be managed by the mechanical switch in the front panel of the CA45. For being able to manage the CL/OL button on the software, the mechanical switch has to be on the state: "Servo ON".

## **7. FIRMWARE UPGRADE**

The application can be upgraded with a new version of software directly from our Web site. An installation sequence as the first installation described in paragraph 4.1.2 is NOT necessary, only the download of the file named HDPM45\_vxx.exe is necessary.

We recommend contacting us and going on our website to download the latest version of the software.

<http://www.cedrat-technologies.com/>

## 8. TECHNICAL SPECIFICATIONS

In the following table, we summarize the technical performances of the UC65.

References	UC65
Function	DSP-based digital controller
Supply voltage	-15/15/5 (Vdc)
Max. number of control channels	3 per board
Sampling time Frequency	16.7 $\mu$ s (1 channel) / 50 $\mu$ s (3 channels) 60KHz (1 channel) / 20KHz (3 channels)
A/D converters	12 channels 16 bits @ +/- 10V
D/A converters	6 channels 16 bits @ +/- 10V
Filter cell @ [minimum cut-off frequency ; maximum cut-off frequency]	2 <sup>nd</sup> order Low-pass filter @ [10 5000]Hz 2 <sup>nd</sup> order stop-band filter @ [10 5000]Hz Two 2 <sup>nd</sup> order stop-band filter in serial independently tuneable @ [10 5000]Hz 4 <sup>th</sup> order stop-band filter @ [10 5000]Hz No filter
Computer interface	USB
Size	Compatible with rack 42F 3H or 84F 4H 6F wide, 3H high
Weight	0.2 Kg

Figure 8-1 : Technical specifications of the UC65 board.

## **9. INSPECTION UPON RECEIPT**

This product has been inspected and shown to operate correctly at the time of shipment, as verified by the Factory Verification Form that accompanies the power supply

Immediately upon receipt of the product, it should be inspected carefully for any signs of damage that may have occurred during shipment. If any damage is found, a claim should be filed with the carrier.

The package should also be inspected for completeness according to the enclosed packing list. If an order is incorrect or incomplete, contact your distributor.